

Temporary Homebuilder Sales Office - Pulte Homes

Pac-Van modular sales office showcases options in upscale property development

This 2,448 sq. ft. building was designed to be a welcome center and sales office. It contains three offices, a children's play area, a large display area, a kitchen and two restrooms. The main focus is a unique half-moon wall display area in the center of the building with can lighting and a lowered circular soffit to accent the curved surface.

The exterior of the building contains the same material that is used in the homes being built in this subdivision. From the stone on the pillars, to the stucco siding, all finishes are options that are available for the homebuyers to select for their new home.

All of the interior walls and floors were unfinished from the factory. This allowed the customer to present the same finishes in the sales center that are available as options in their new homes. It also provided additional cost savings.

The entire lighting package was hand selected to provide high performance and an 89+ % energy saving versus incandescent lights. All lights have an 80% or higher efficiency rating.

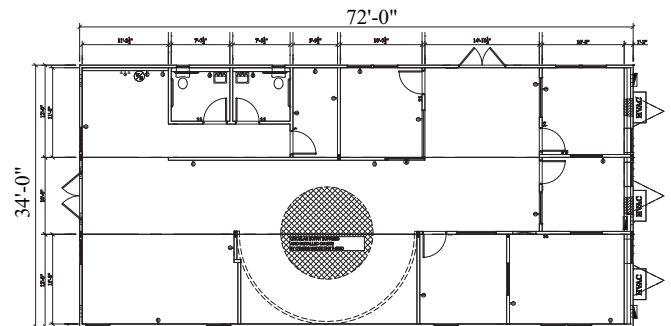

Experience You Can Trust - Quality You Demand

When time is of the essence, the quick construction of modular buildings make them ideal for residential sales offices. Pac-Van offers flexible lease or purchase plans.

Learn more about modular buildings at:

www.pacvan.com/modular-sales-office.aspx

Nationwide **800.587.1784**

We've put thousands of U.S. businesses in space™
Modular Buildings - Mobile Offices - Storage Equipment

