

Tough as nails! All-steel Ground-level Offices

Tough, secure, affordable and relocatable solution to on-site security concerns

No set-up charges. Relocate as needed.
Two units can stack with exterior stairs.

- Heavy 14 guage all-steel construction
- Proprietary heavy locking mechanism
- Welded steel window security bars
- Built-in plan table, desk, file cabinet
- Wall mounted J-box for phone/data
- R11 insulation in office areas
- Fully lined with VCG interior finish
- Air conditioning & heat installed
- Fluorescent office lighting
- 1/8" commercial block tile office floor

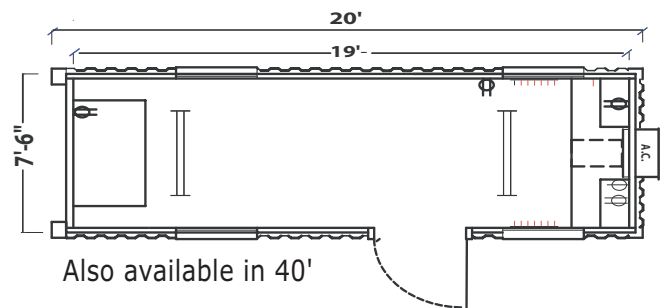
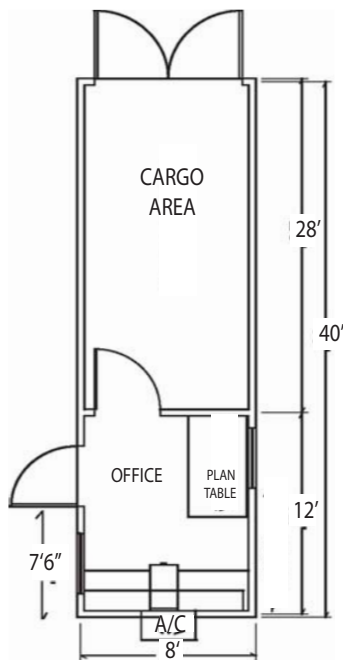

We pick up and deliver nationwide
Let us know where and when. Depending on location, we can often have your office on site within 24 hours. Ask us about our flexible rent, lease or purchase plans. Find out more about all-steel security offices www.pacvan.com/ground-level-offices.aspx

Nationwide 800.587.1784

**We've put thousands of U.S. businesses in space™
Modular Buildings - Mobile Offices - Storage Equipment**

